

Sew **WHAT?**

M A G A Z I N E

The International Magazine for Custom Home Furnishings Professionals

Volume 11, Number 4

April 2003

2003 Heimtextil Show *Threads, Threads, Threads!*

Modified Celebration Valance

Woven Leather Pillow

Mikado Shade

Terrific Trims - Pillows



S29 P8 *****MIXED ADC 280

KAREN BARNES
THE ELEGANT WINDOW
4107 E ENCINAS AVE
HIGLEY AZ 85236-3329

Modified Celebration Valance

By Karen Barnes



This treatment is an adaptation of Pate-Meadows pattern, Celebration Valance, which is also referred to as a Southern Living pattern. To purchase the pattern, go to www.patemeadows.com and click on the link to Southern Living magazine.

I really liked this Southern Living Celebration Valance when it was requested by one of my clients. After making modifications for her treatment, I liked it even more! In fact, I liked it so much that I made this pattern for my own kitchen bay window. I decided to take out some of the fullness in the horn and cascade patterns and widen the flat swag sections. I also made the cascades longer. I wanted to attach the valance to finials that had been mounted directly into the wall, so I also eliminated the returns on the cascades.

To determine swag size, measure the finished width of the window treatment and divide that by the number of swags desired. Then, from this swag size, subtract 2½" for each horn and 3" for each cascade. The size of the swag sections for my kitchen bay window is one 25" for the small side windows and two 27" for the larger center bay window. I recommend that the flat swag sections be no larger than 27". To make the flat swag section wider than the Celebration pattern, slit the pattern down the center and widen it to the size you need. You may need to adjust the top and bottom curve lines. I also adjusted the sides of the swag pattern so that they didn't flare out as much and

changed the side dimension to 15½" so that the seams would match when sewing the swag to the cascade. See Illustration 1. Adjust the horn and cascade pattern pieces, as in illustrations 2 and 3, respectively. The horn and cascades are contrast or self-lined. The swags are lined with thermal suede lining.

1. If using banding, sew or glue banding on to each piece first. I made my banding 1¼" finished width (2¼" cut width) and applied it with iron-on tape.
2. Sew the pieces together as for the Celebration Valance pattern instructions: i.e., cascade right short point is sewn to left side of swag, then right side of swag to left side of horn, then right side of horn to left side of swag, then right side of swag to cascade left short point.
3. Sew the lining pieces together, the same as the face fabric pieces.
4. Sew the face fabric and lining together, right sides together, sewing along the side of the cascades and all across the bottom using ½" seam allowance. Sew the tops of the swag sections together, stopping at the seams. The only parts remaining which are not sewn together are the tops of the cascades and horns.

5. Before turning the valance right side out, take a ½" vertical snip right next to the seam allowance where the cascade/horn and swag pieces are seamed together, at the top. Clip the point of the cascade.
6. Turn inside out through one of the open sections. Press.
7. Make decorative tabs (optional.) Sew right sides together, leaving the top free. Clip, turn, and press. See Illustration 4.

In the following steps, you will be making a casing to attach to the top of the cascades or horn. A shade cord will be pulled through the casing and then tied around the finial. This gathers the cascades and horn, creating soft folds.

8. Cut bias strips 2" x 17". Fuse or glue down the short ends of bias strips to eliminate raw edges.
9. Center the decorative tab onto the cascade. Baste.
10. Center the bias strip to the cascade or horn. (Make sure to have the right side of the bias strip to the wrong side of the cascade or horn.)
11. Sew the bias strip to the horn or cascade, using a ½" seam allowance. Press toward the top.
12. Press a ½" fold in the bias strip (the side that is not sewn to the cascade or horn.)



13. Fold the bias strip over the top of the cascade or horn to form a casing and top stitch near the edge of the casing.
14. Push a loop turner through the casing and with the hook, pull shade cord or string back through the casing. (If you don't have a loop turner, place a shade cord onto the casing before folding it over and stitching it down. The cord will already be in the casing and you won't have to push it through with a safety pin.)
15. To tie the casing around the finial, pull tight and tie the shade cord securely. This will create soft folds in the cascade or horn.
16. Trim the excess shade cord and hide the tails of the shade cord behind the valance. Don't cut off too much extra shade cord in case you have to take the valance down in the future.
17. If you are mounting this valance to a decorative pole, do not eliminate the returns.

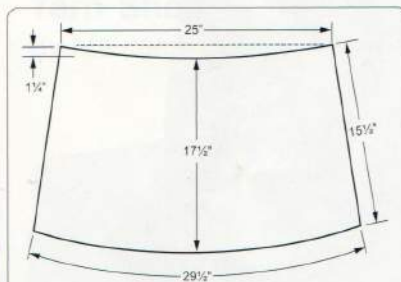
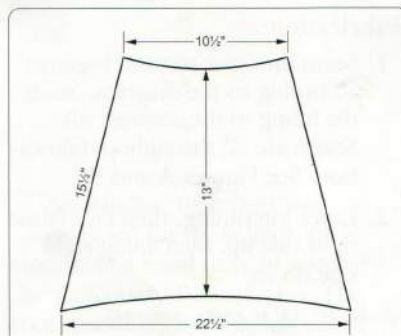

Illustration 1 - Flat Swag Section

This pattern piece is for the side bay window. Decide on the finished width of the window. Subtract 2 1/2" for each horn and 3" for each jabot. (Side bay windows do not have a horn.) Split this pattern down the center to widen or make more narrow.



*Illustration 2
Center Horn*

Modifications to pattern piece:

- Tab is eliminated.
- Some fullness is taken out.
- Contrast or self-line.

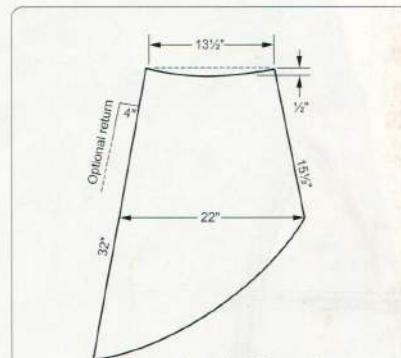
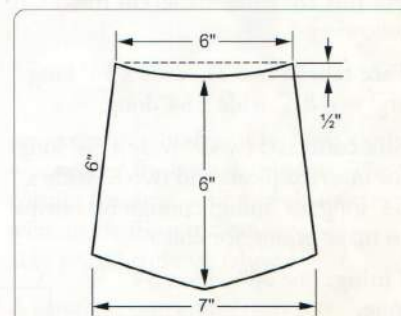

Illustration 3 - Cascade

Modifications to pattern piece:

- 7" longer than the Celebration Valance pattern.
- Short point doesn't flare out as much.
- Return is eliminated if attaching the valance to finials.
- Tab portion is eliminated at the top.
- Contrast or self-lined.



*Illustration 4
Self-Lined Decorative Tab (Optional)*

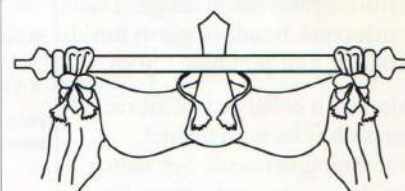

Illustration 5

If the valance is mounted on a pole, do not eliminate the tab portion of the horn/jabot pattern. A cute idea, if mounting on a pole, draw a slight point on the end of the tab pattern on the Celebration Valance. Sew around the tab but do not attach the tab to the front of the valance by sewing it down as in the pattern instructions. Instead, wrap the tab over the pole and secure it to the valance by tying a tassel.



Karen Barnes is the owner of The Elegant Window, in Gilbert, Arizona, serving both retail and wholesale clients. She is a member of the WCAA and the Arizona Window Covering and Design Association. Karen is a Certified Workroom Professional.